

# UTSL series SECURITY LUMINAIRE

## UTSL-100ZT



### Features :

- © High-pressure die cast aluminum alloy casing with electrostatic painted surface, Corrosion-resistance and durable use
- © Heat-resistant acrylic hood
- © Intelligent infrared sensor for dusk to dawn operation

### Lamp and ballast :

- © Ultra-Tech's 40W ~100W round tubular or 40W~80W mogul type tubular induction lamps feature superior lighting efficiency, producing more visually effective lumens (VEL) per watt than other lighting sources
- © Rated lamp life of 60,000~100,000 hours, the equivalent of 11 years at 24 hours per day, 365 days per year with a warranty of 10 years or 50,000 hours which ever comes first
- © Instant strike, flicker free, no cool down required, insensitive to numbers of on off, fast warm-up
- © Induction lamps are full spectrum containing R/G/B and C/M/Y resulting in a high CRI

### Applications :

- © For the floodlighting of roadway, buildings, garden

### Installation :

- © Installation method must allow for free airflow around the ballast to comply with warranty requirements



### Dimensions :

Unit: inches (mm)

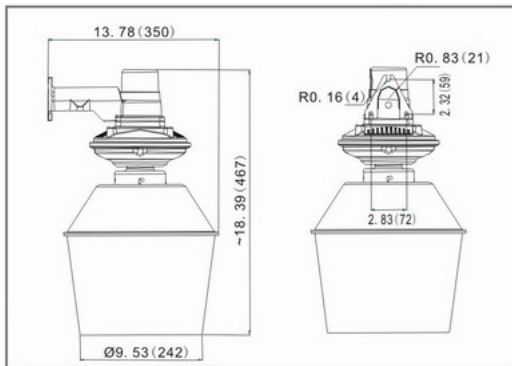

### Fixture Specifications :

No.	Fixture Model No.	Lamp	Wattage (W)	Lamp lumens (Lm)	Voltage (V)	Color Temperature (K)	Ambient (°C)	Installation	IP class	Note	UL CUL
1	UTSL-100ZT	RT40W	40	2600-3000	100-300	5000	-20~+50	Round pole	IP55 (Control gear)		√
		RT70W	70	4900-5600							
		RT80W	80	5600-6400							
		RT100W	100	7500-8500							

\* Note: Color Temperature 2720-6500K available upon request.